

Apeldoorn

Baron Sloetkade 287 | Vraagprijs € 375.000 k.k.

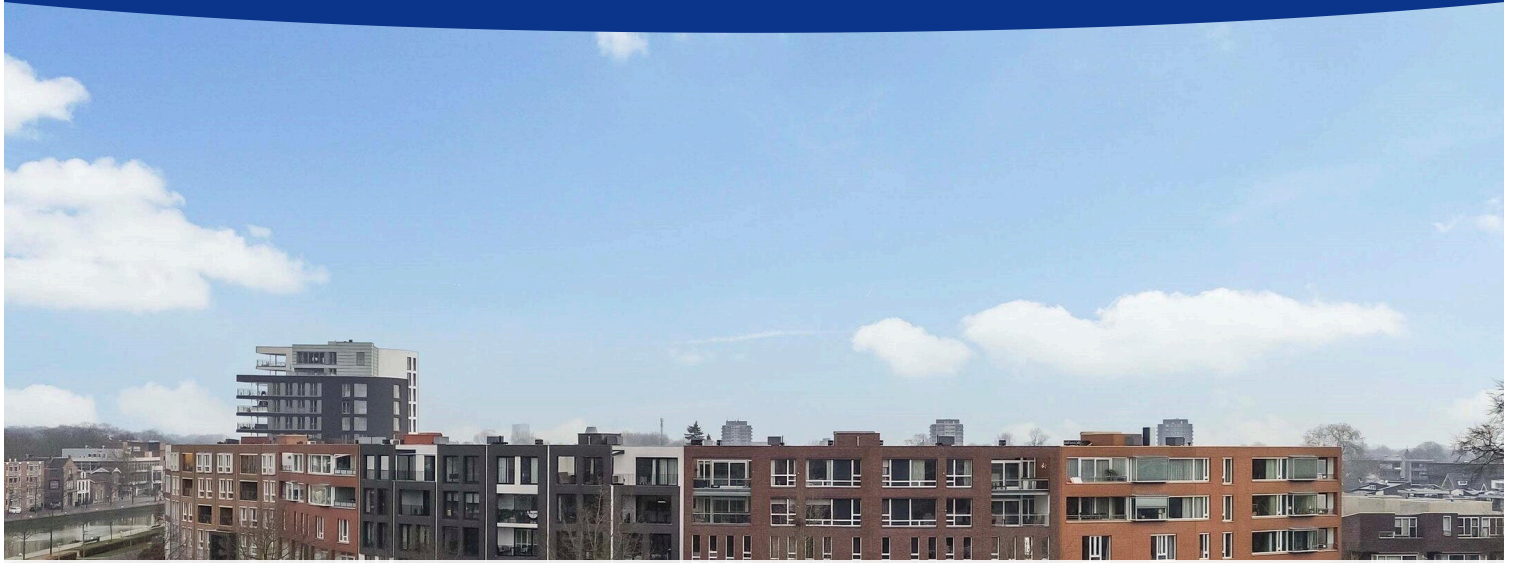

BESCHIKBAAR

WWW.BARONSLOETKADE287.NL

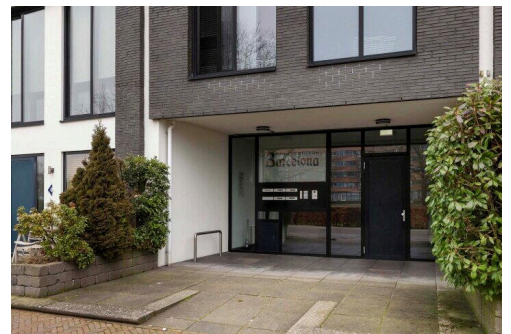
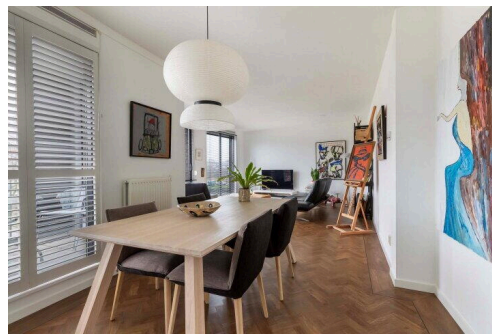
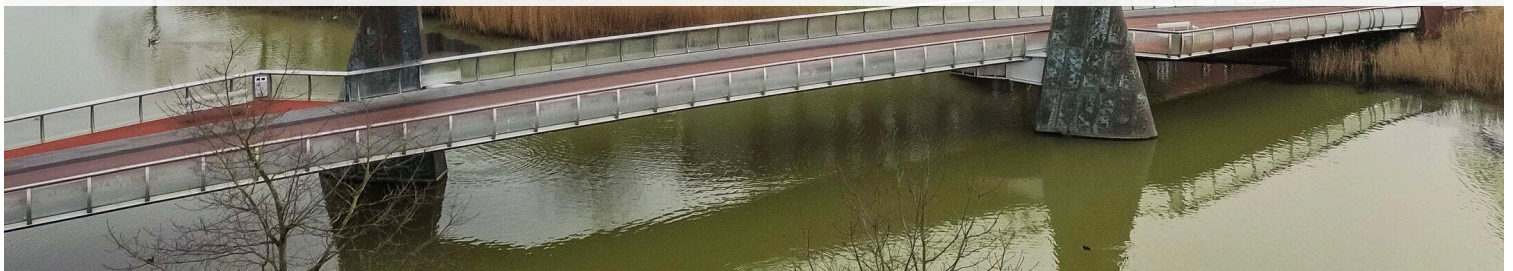

| | |
|-------------------------|--|
| Type object: | Maisonnette (appartement) |
| Bouwjaar: | 2007 |
| Woonoppervlakte: | 79 m ² |
| Inhoud: | 267 m ³ |
| Aantal kamers: | 3 kamers (1 slaapkamer) |
| Website: | www.baronsloetkade287.nl |



Omschrijving

Baron Sloetkade 287, 7321 ZX Apeldoorn

For english see below

Modern en comfortabel appartement op toplocatie

Dit ruime en lichte appartement aan de Baron Sloetkade, direct gelegen aan het Apeldoorns Kanaal, biedt een unieke woonervaring. Het appartement bevindt zich op de eerste en tweede verdieping van het appartementencomplex "Barcelona" en heeft een oppervlakte van 79m².

Indeling

Eerste verdieping: Slaapkamer met aangrenzende badkamer.

Tweede verdieping: Lichte woonkamer met open keuken, separaat toilet en balkon.

Het balkon biedt een aangenaam buitenverblijf met uitzicht over het Apeldoorns Kanaal en de stad.

Uitstekende voorzieningen en bereikbaarheid

Het appartement is gelegen op loopafstand van diverse voorzieningen, waaronder:

- Het treinstation
- Het centrum van Apeldoorn
- Uitgaansgelegenheden
- Huisartsenpraktijk en apotheek
- Sportscholen en supermarkten

Daarnaast bevinden de Veluwe bossen zich op slechts 4 kilometer afstand.

Privé parkeergelegenheid

De woning beschikt over een afsluitbare garage met een vloeistofvrije gietvloer, een zeldzame luxe in het centrum van Apeldoorn.

Vereniging van Eigenaren (VvE)

De maandelijkse VvE-bijdrage bedraagt:

€83,- voor de woning

€46,62 voor de garage

Dit appartement combineert een centrale ligging met comfort en privacy.

Neem contact op voor meer informatie of een bezichtiging.

Modern and Comfortable Apartment in a Prime Location

This spacious and bright apartment on Baron Sloetkade, directly located along the Apeldoorn Canal, offers a unique living experience. Situated on the first and second floors of the "Barcelona" apartment complex, it has a total area of 79m².

Layout

First floor: Bedroom with en-suite bathroom.

Second floor: Bright living room with an open kitchen, separate toilet, and balcony.

The balcony provides a pleasant outdoor space with views over the Apeldoorn Canal and the city.

Excellent Amenities and Accessibility

This apartment is within walking distance of various essential facilities, including:

The train station

Apeldoorn's city center

Entertainment venues

A medical practice and pharmacy

Gyms and supermarkets

Additionally, the Veluwe forests are just 4 kilometers away, perfect for outdoor activities.

Private Parking

The property includes a secure private garage with a liquid-resistant cast floor, a rare luxury in the city center.

Homeowners' Association (VvE)

The monthly VvE contribution is:

€83 for the apartment

€46.62 for the garage

This apartment offers a perfect combination of central location, comfort, and privacy. Contact us for more information or to schedule a viewing.

Kenmerken

| | |
|---------------|-------------------|
| Vraagprijs: | € 375.000 k.k. |
| Aanvaarding: | In overleg |
| Bijdrage vve: | € 83,00 per maand |

Bouw

| | |
|--------------|--|
| Object type: | Maisonnette (appartement) |
| Soort bouw: | Bestaande bouw |
| Bouwjaar: | 2007 |
| Soort dak: | Plat dak bedekt met bitumineuze dakbedekking |

Oppervlakte en inhoud

| | |
|------------------------------|--------------------|
| Woonoppervlakte: | 79 m ² |
| Inhoud: | 267 m ³ |
| Externe bergruimte: | 23 m ² |
| Gebouwgebonden buitenruimte: | 10 m ² |

Indeling

| | |
|------------------------|--|
| Aantal kamers: | 3 kamers (1 slaapkamer) |
| Aantal badkamers: | 1 badkamer en 1 apart toilet |
| Badkamervoorzieningen: | Douche, inloopdouche, en toilet |
| Aantal woonlagen: | 2 woonlagen |
| Voorzieningen: | Airconditioning, glasvezelkabel, lift, en mechanische ventilatie |

Energie

| | |
|----------------|---|
| Energie label: | A |
| Isolatie: | Dakisolatie, hr-glas, muurisolatie en volledig geïsoleerd |
| Verwarming: | Cv-ketel |
| Warm water: | Cv-ketel |
| Cv ketel: | Remeha (gas gestookt uit 2018, eigendom) |

Buitenruimte

| | |
|----------|--|
| Ligging: | Aan rustige weg, aan water, in centrum, in woonwijk en vrij uitzicht |
|----------|--|

Bergruimte

| | |
|---------------------------|---------------|
| Schuur berging: | Inpandig |
| Voorzieningen schuur: | Elektra |
| Soort parkeergelegenheid: | Parkeergarage |

Garage

| | |
|-----------------------|-----------------------------|
| Soort garage: | Garagebox |
| Capaciteit garage: | 1 auto |
| Voorzieningen garage: | Elektrische deur en elektra |

VvE Checklist

| | |
|-------------------------|------------------------|
| Inschrijving kvk: | Ja |
| Jaarlijkse vergadering: | Ja |
| Periodieke bijdrage: | Ja (€ 83,00 per maand) |
| Reservefonds aanwezig: | Ja |
| Onderhoudsplan: | Ja |
| Opstalverzekering: | Ja |

Op de kaart

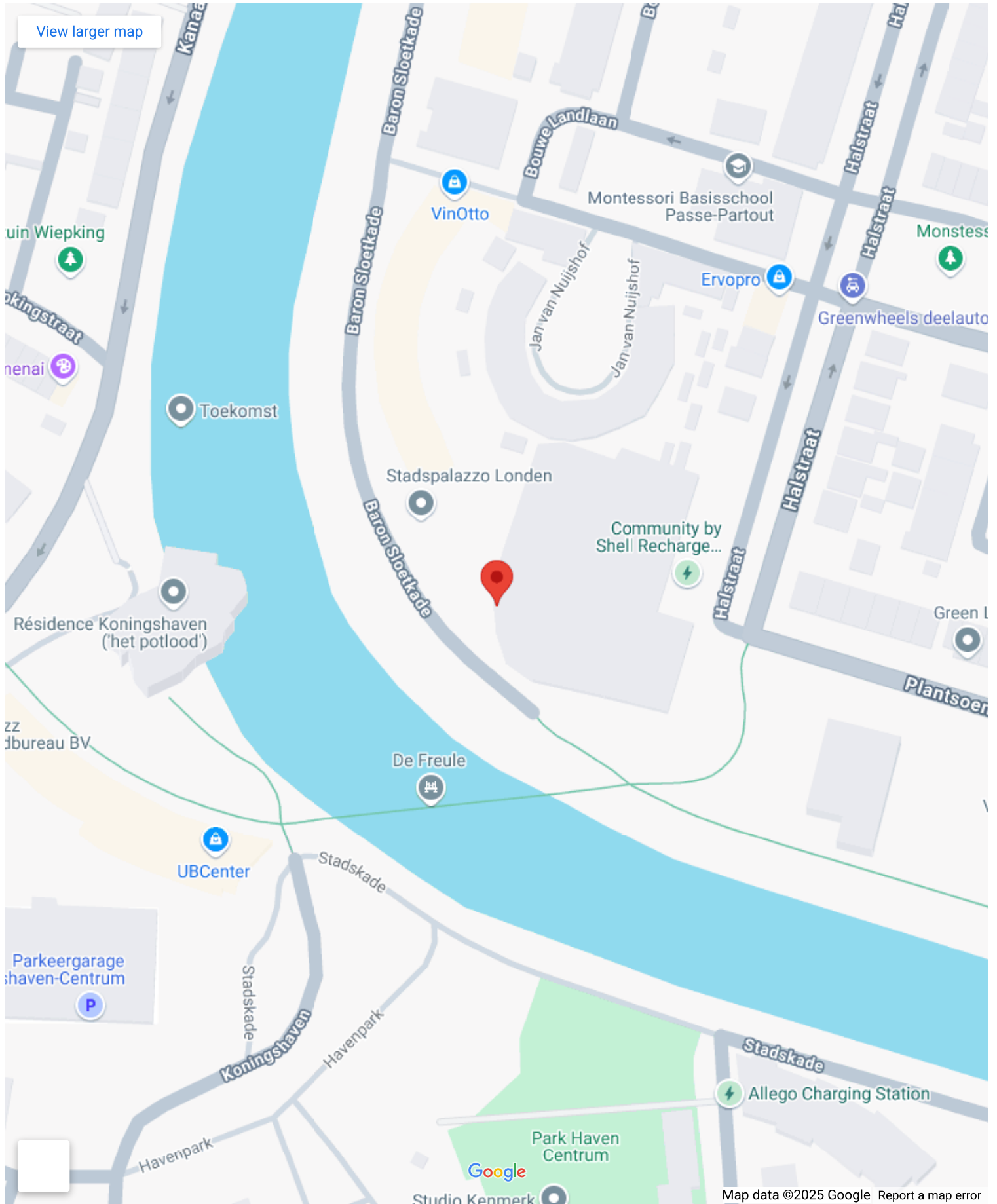

Op de kaart

Baron Sloetkade 287

Baron Sloetkade 287, 7321 ZX
Apeldoorn

[Directions](#)

[View larger map](#)

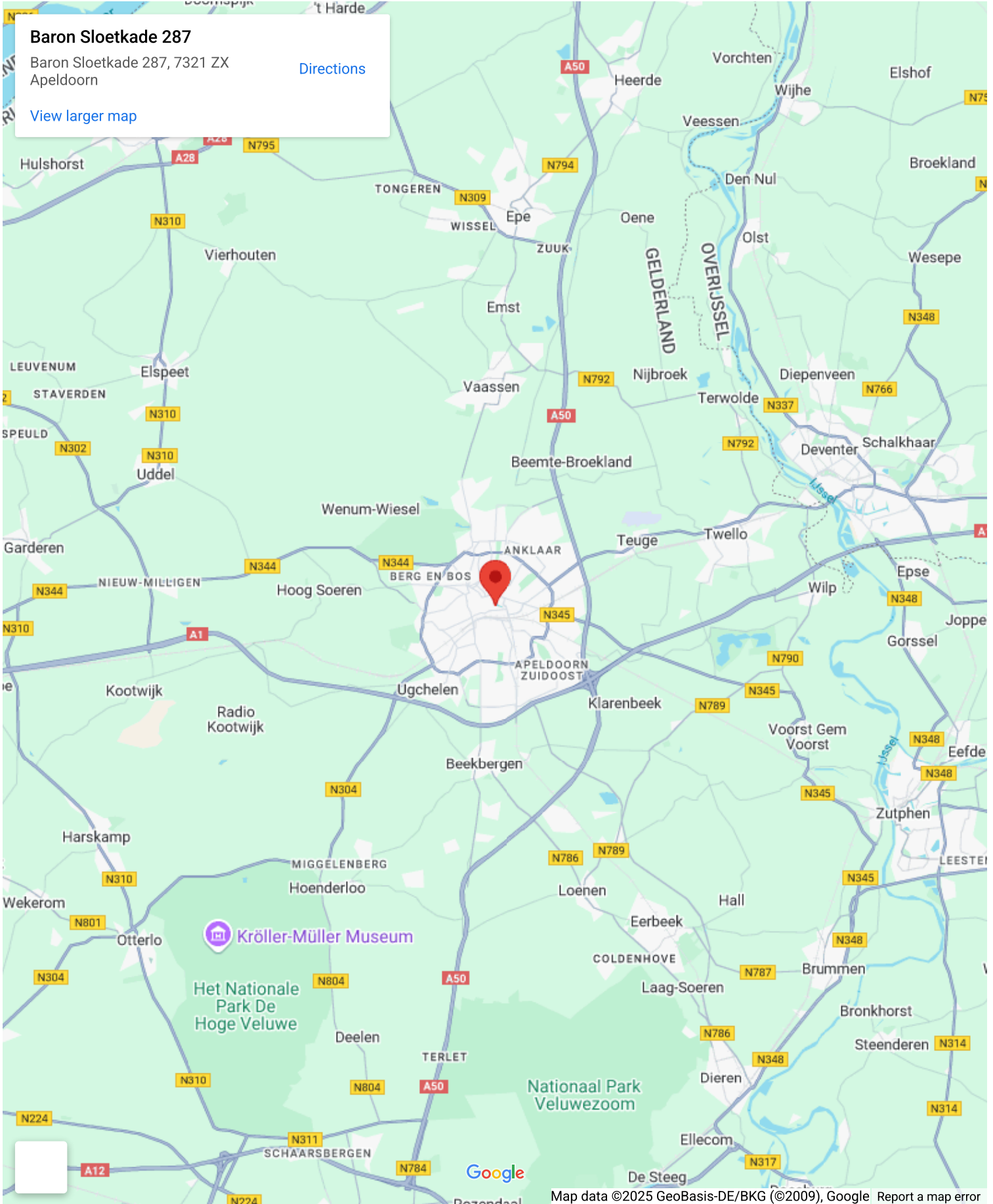

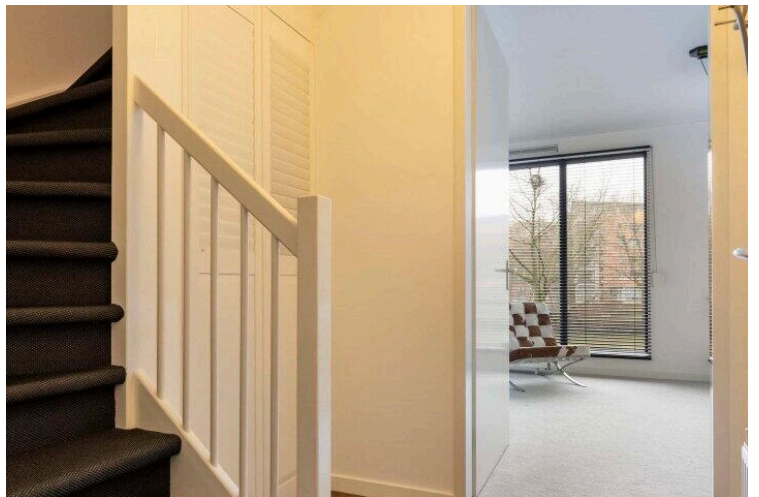
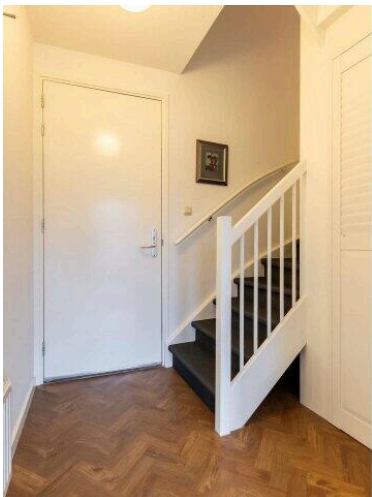
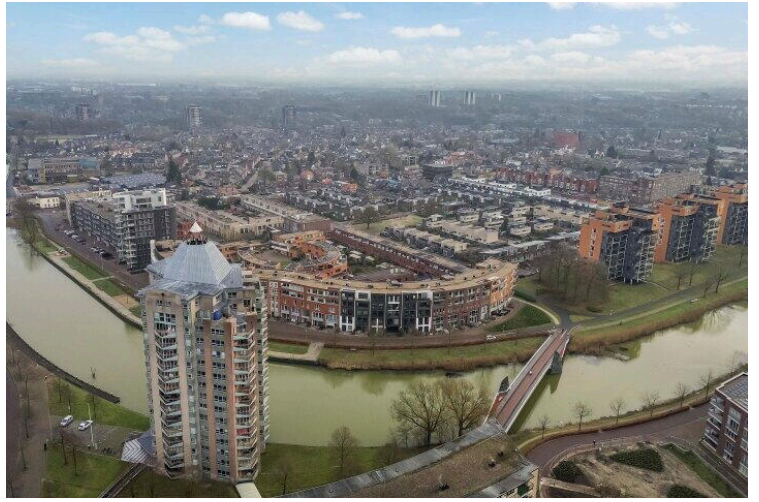
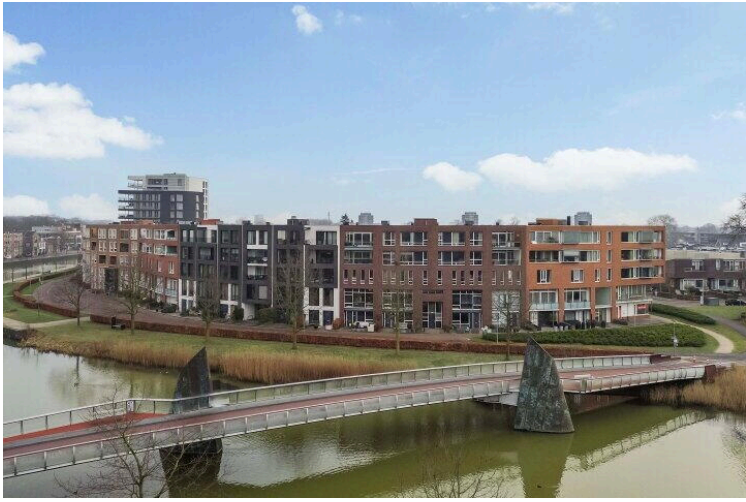

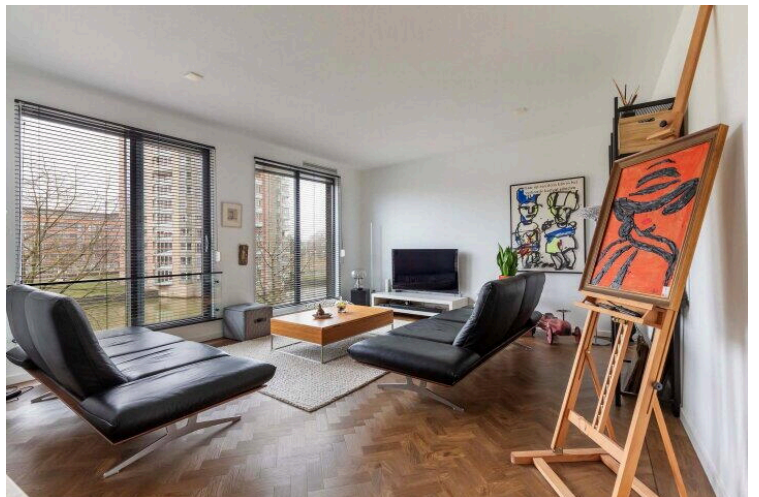
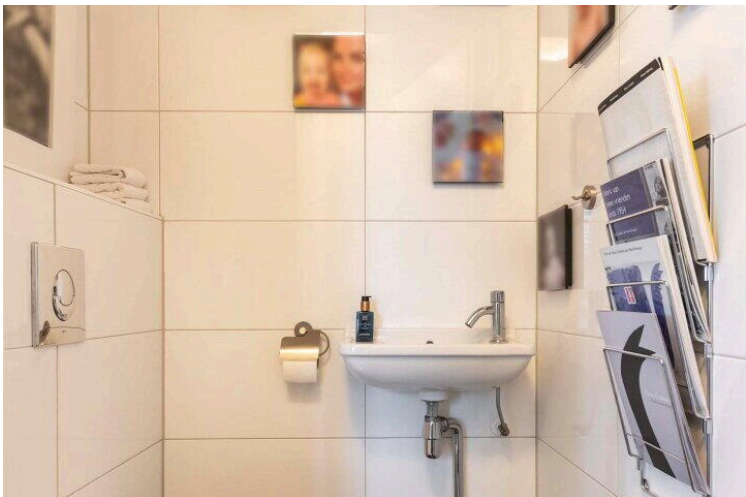
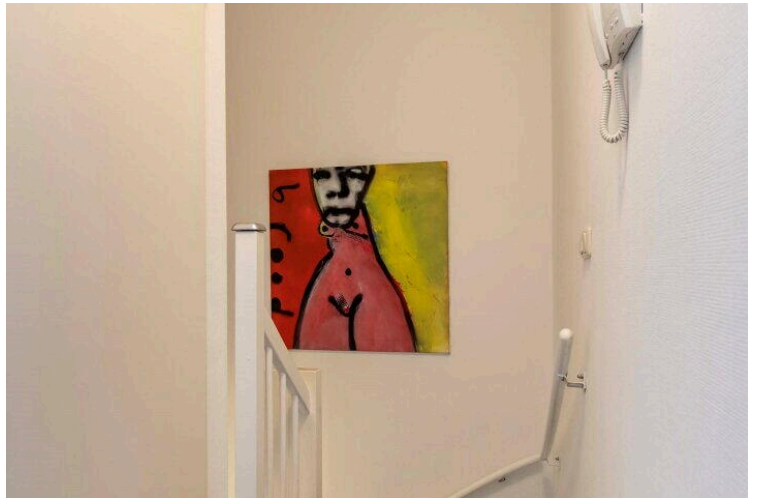

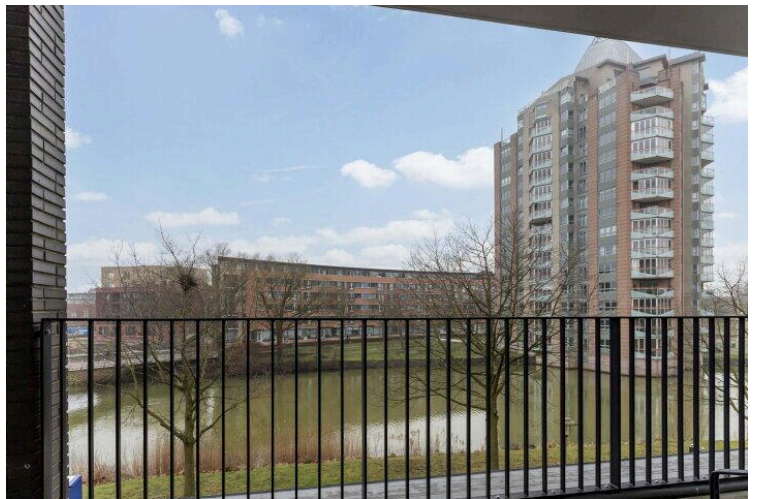
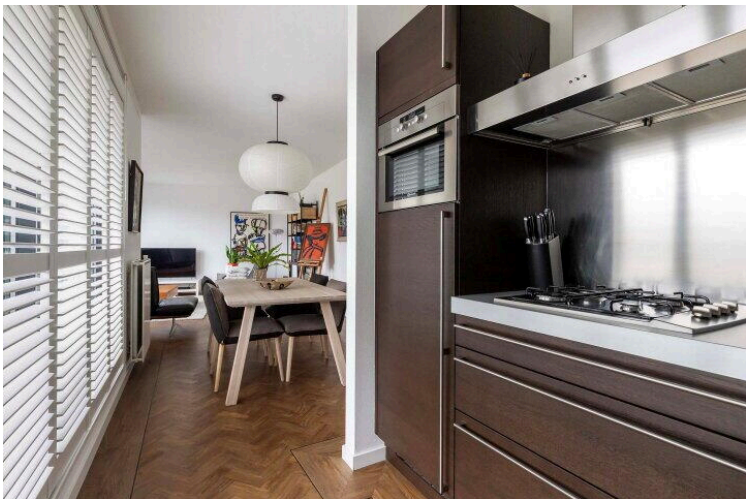
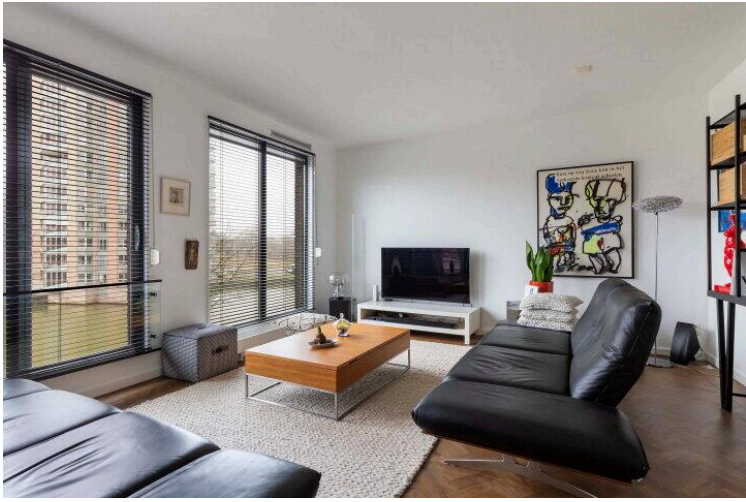

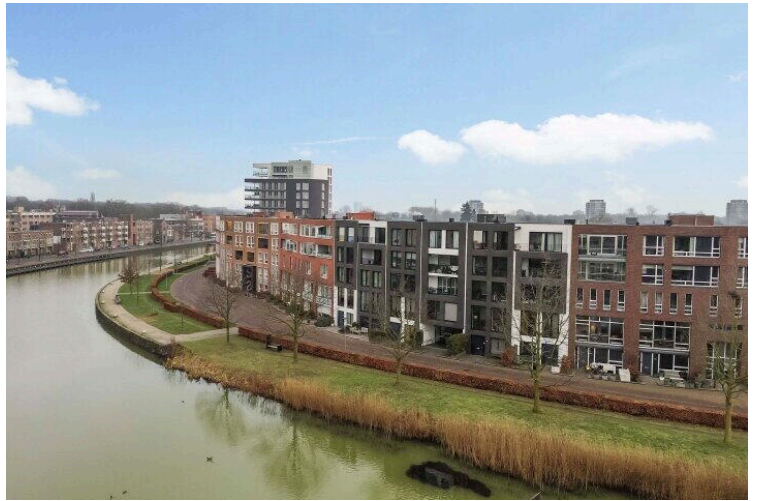
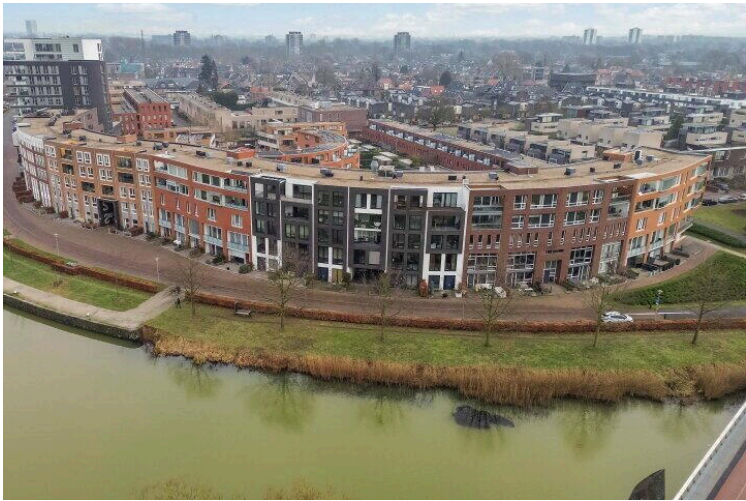
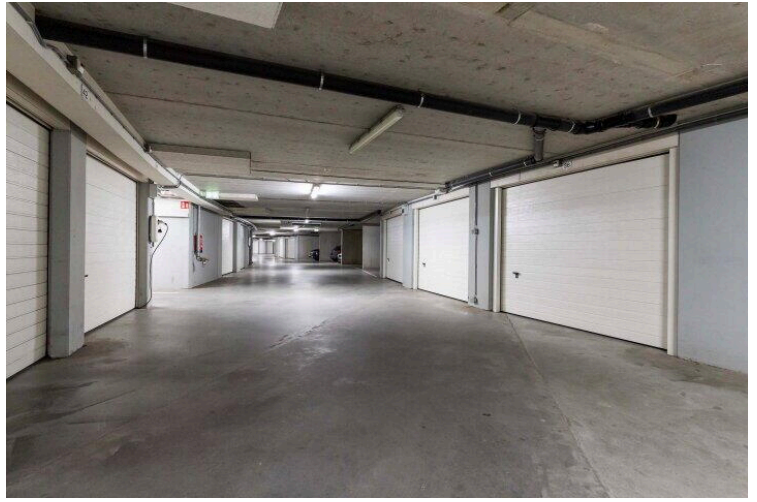

Baron Sloetkade 287 Apeldoorn
1e verdieping



De plattegronden zijn met de grootste zorg samengesteld.
Aan deze plattegronden kunnen geen rechten worden ontleend.

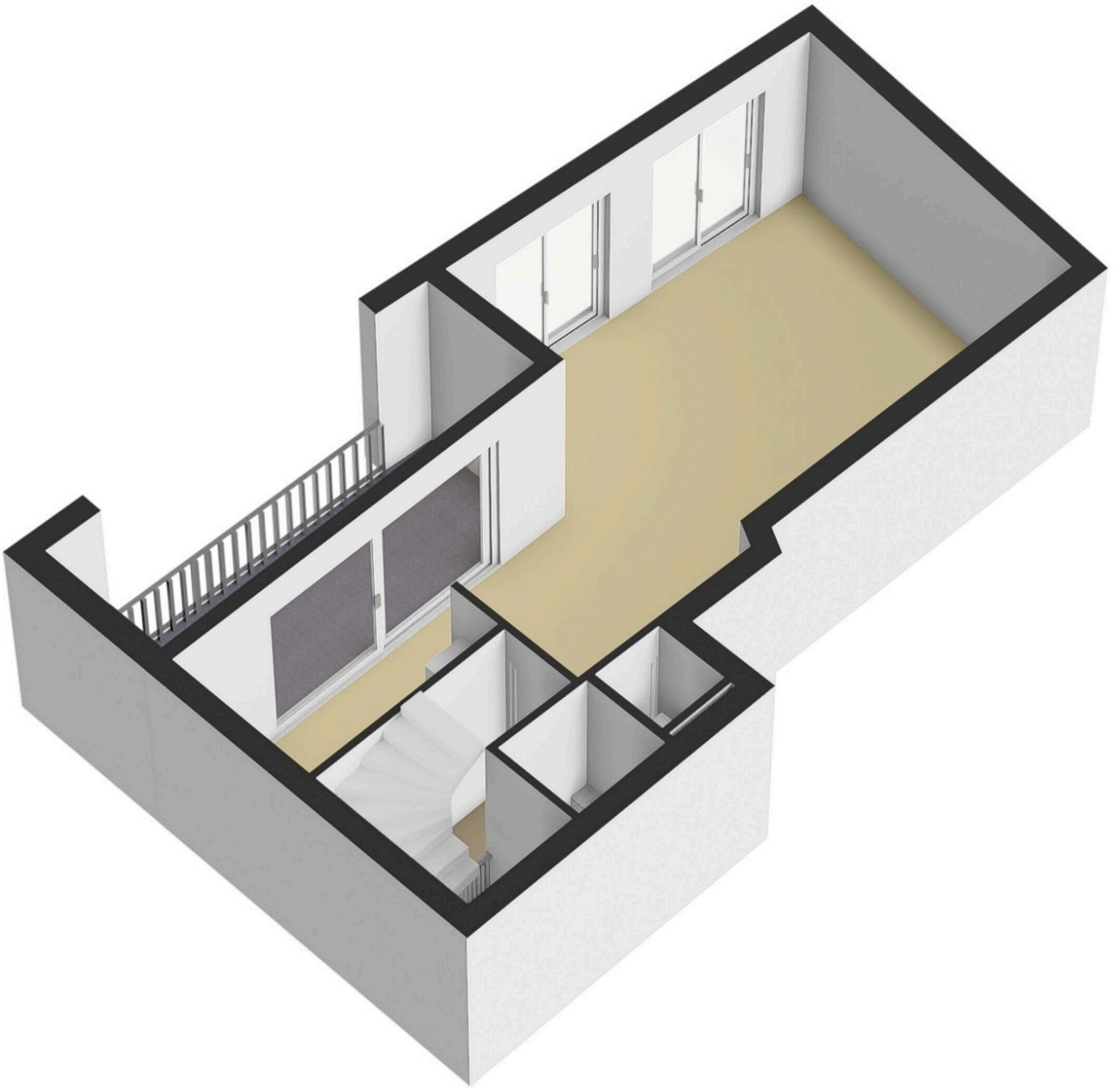

Baron Sloetkade 287 Apeldoorn
Begane grond

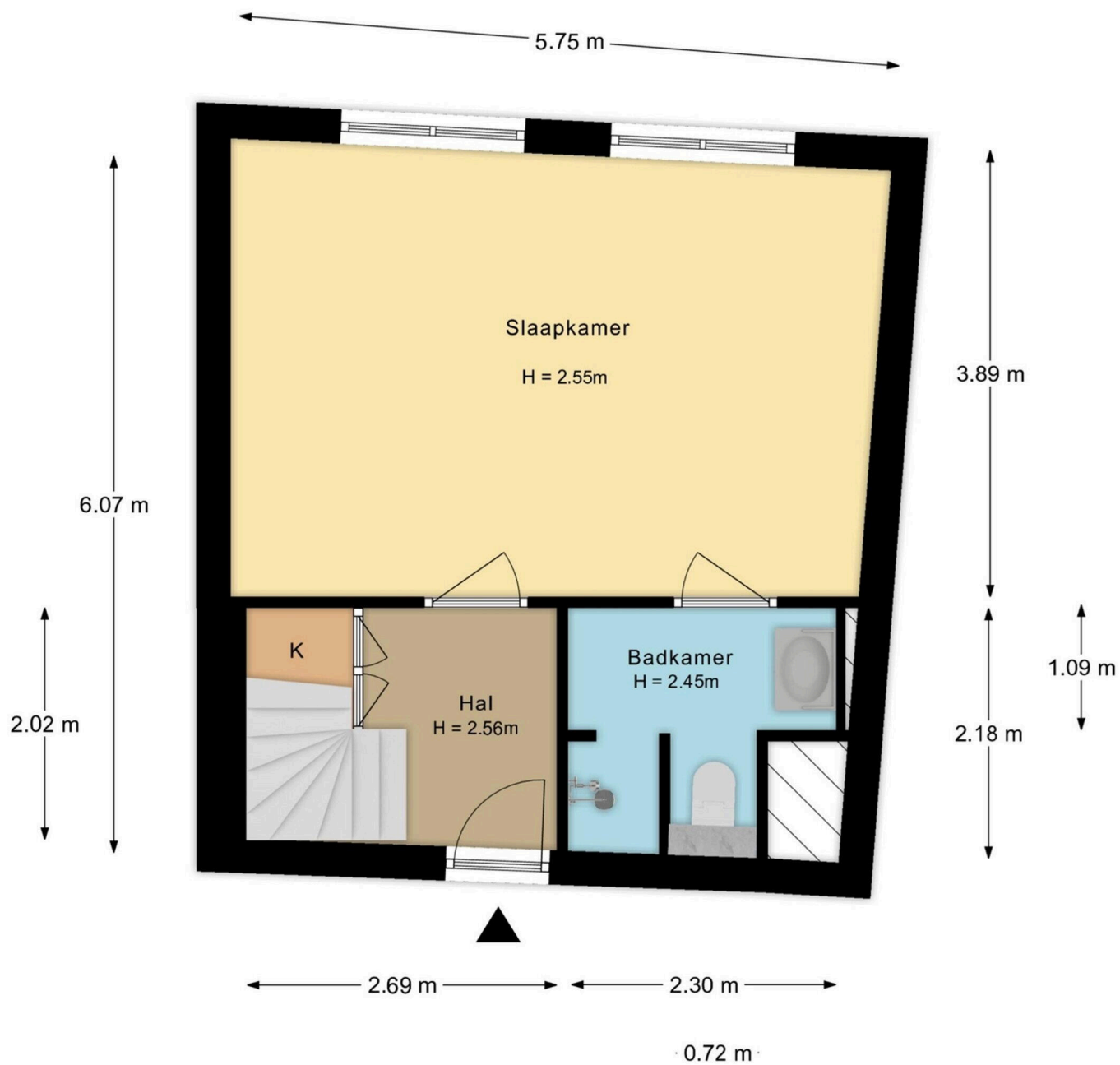

De plattegronden zijn met de grootste zorg samengesteld.
Aan deze plattegronden kunnen geen rechten worden ontleend.

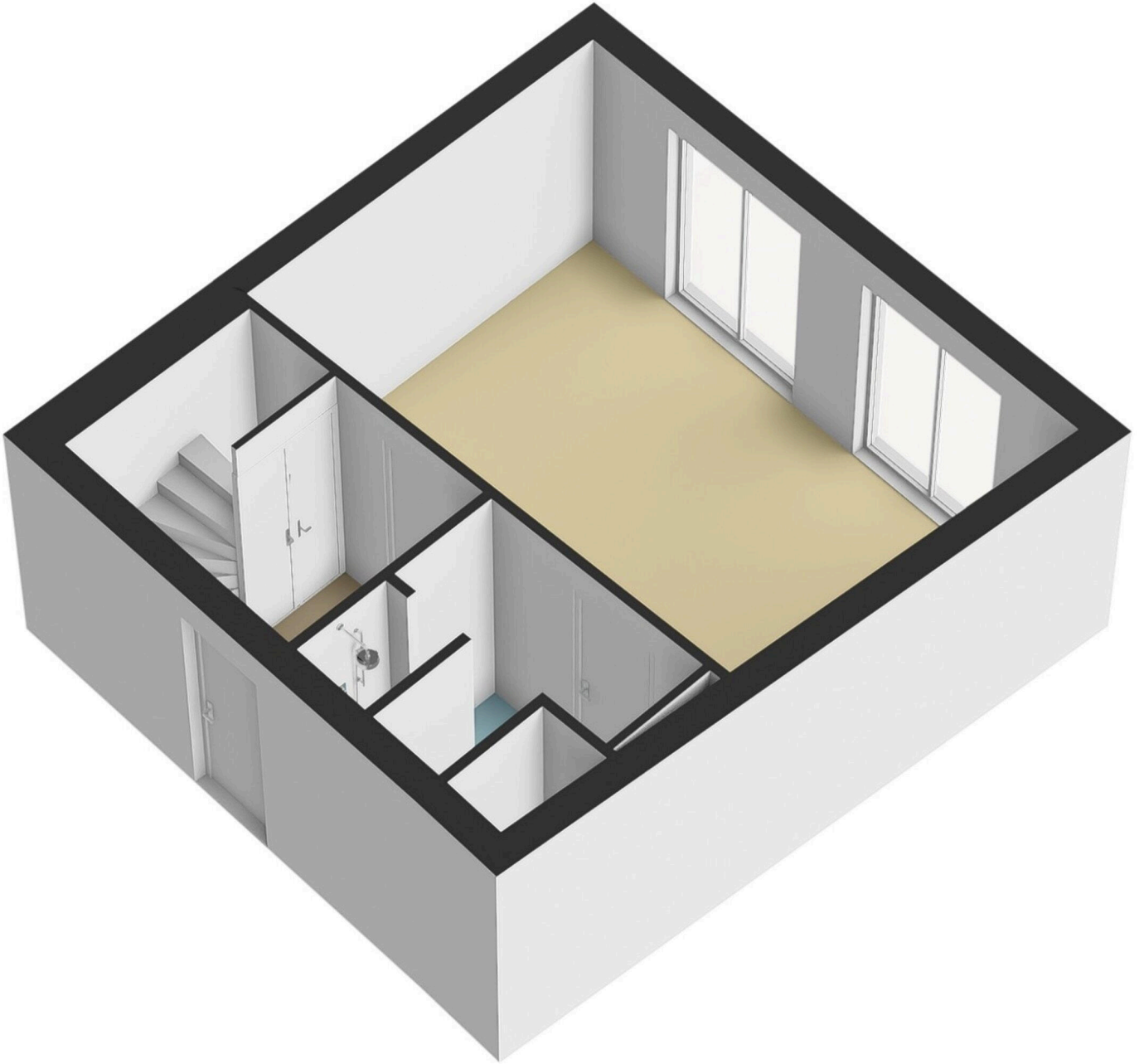

Baron Sloetkade 287 Apeldoorn
Berging

← 2.15 m →

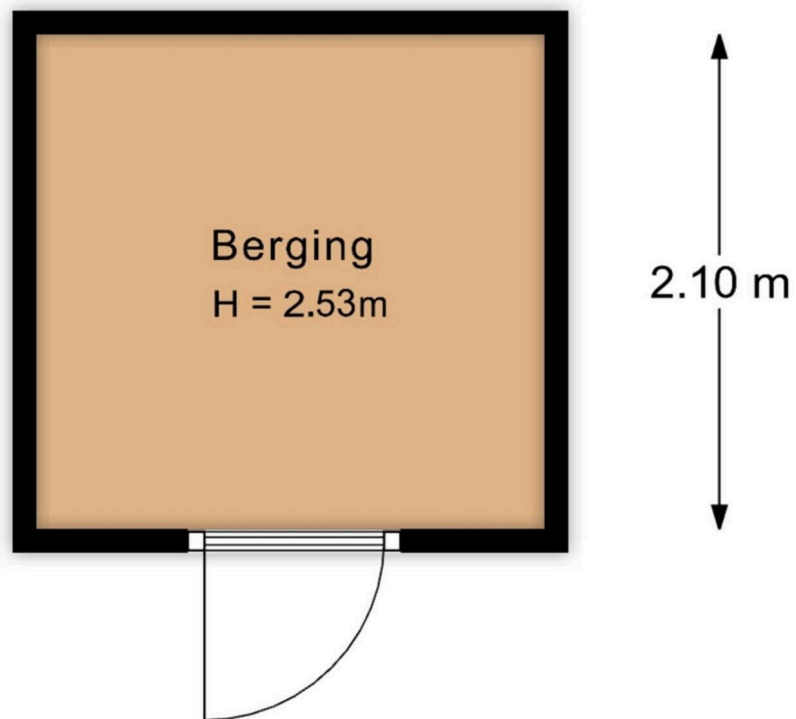

De plattegronden zijn met de grootste zorg samengesteld.
Aan deze plattegronden kunnen geen rechten worden ontleend.

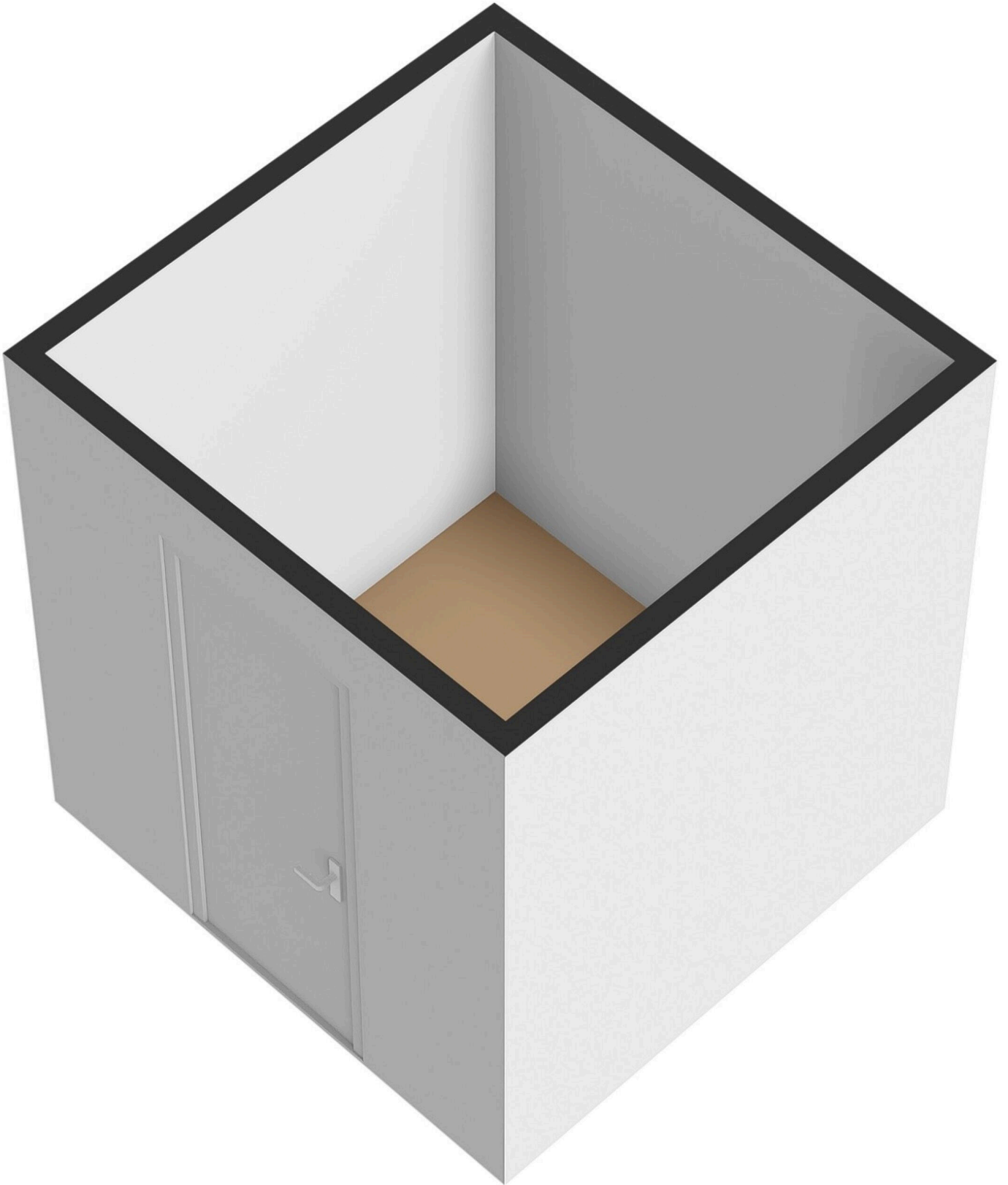

Baron Sloetkade 287 Apeldoorn
Garage

← 3.50 m →

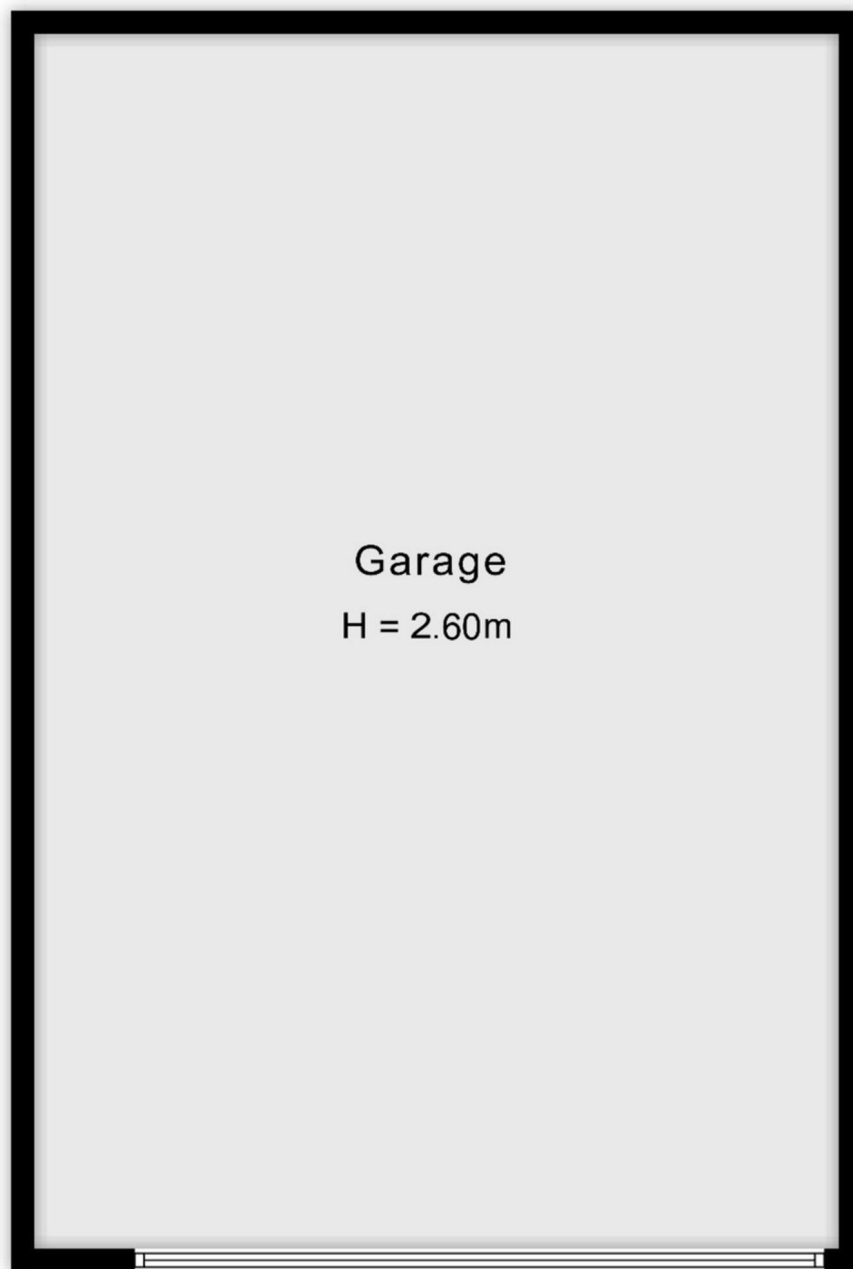

5.30 m

De plattegronden zijn met de grootste zorg samengesteld.
Aan deze plattegronden kunnen geen rechten worden ontleend.

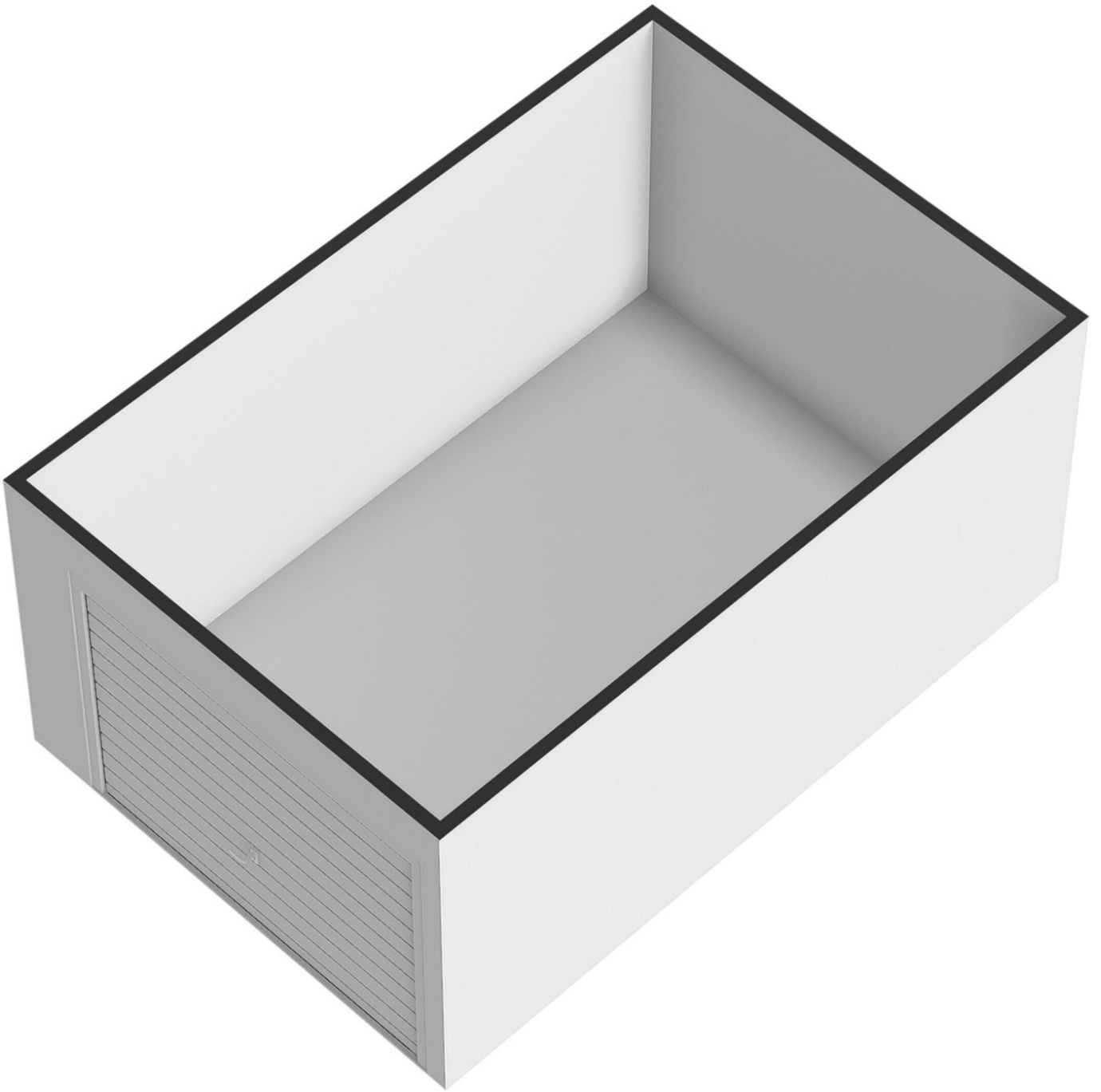

Baron Sloetkade 287

www.baronsloetkade287.nl



WitteWoning Makelaars Apeldoorn

De Eglantier 404
7329 DL, Apeldoorn

www.wittewoningmakelaars.nl
055 202 00 10

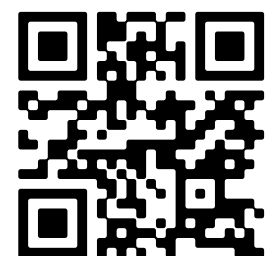

Scan Mij!